

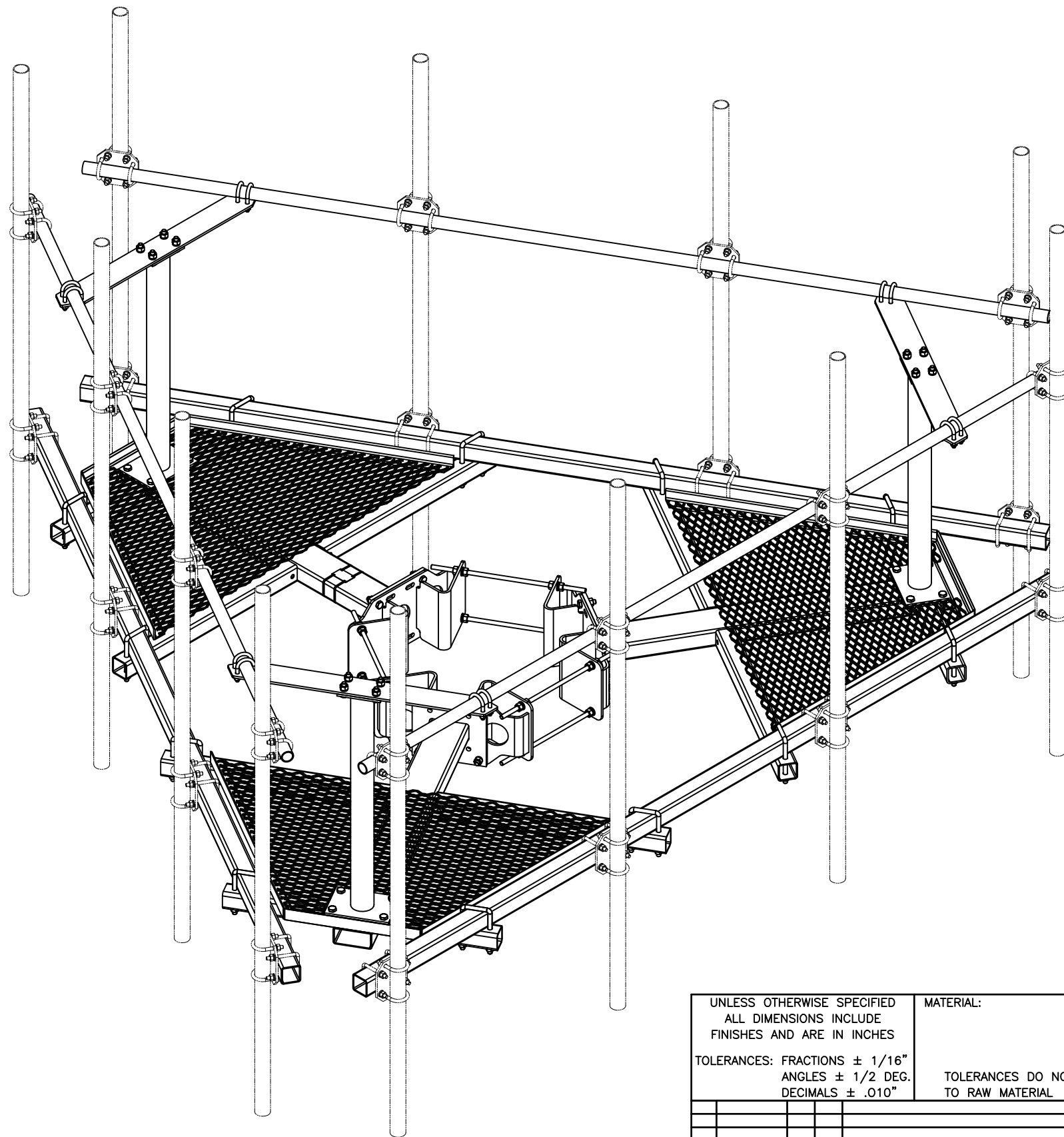

C10855661C 12' HC PLATFORM W/ENHANCED SUPPORT RAIL & COLLAR

ITEM	QTY.	PART NO.	DESCRIPTION	WEIGHT
1.	1	C10112377	TRI-COLLAR BRACKET ASSEMBLY (10"-40" MONOPOLE)	208
2.	3	CW01320	WELDMNT, PLATFORM CORNER	612
3.	3	CS03348	SQUARE TUBE, 3 X 3 X 3/16 X 12'-6	268
4.	3	CW01321	WELDMNT, POST 3 1/2" O.D. X 3'-4	107
5.	3	CS03349	PLATE, CONNECTION 3/8 X 4 3/8 X 3'-6 1/16	56
6.	3	CS02229	PIPE, 1.9 O.D. X .145 X 12'-6	106
7.	12	C40026024	BOLT ASSEMBLY, 5/8 Ø X 2 1/4 A325	6
8.	24	C40026023	BOLT ASSEMBLY, 5/8 Ø X 2 A325	11
9.	12	C40035017	SQ. U-BOLT ASSEMBLY, 5/8 Ø X 4 1/4 C-C	25
10.	12	C40034060	U-BOLT ASSEMBLY, 1/2 Ø X 2 9/16 C-C	9
11.	1	Z30992010	MOUNT CLASSIFICATION TAG C10855661C	1
12.	2	C40062104	STAINLESS STEEL SELF-LOCKING CABLE TIE	1

TOTAL WEIGHT 1410



MOUNTING PIPES & CROSSOVER PLATE KITS MUST BE PURCHASED SEPARATELY

ISOMETRIC VIEW

SEE PAGE 2 FOR ADDITIONAL DETAILS

UNLESS OTHERWISE SPECIFIED ALL DIMENSIONS INCLUDE FINISHES AND ARE IN INCHES
TOLERANCES: FRACTIONS ± 1/16"
ANGLES ± 1/2 DEG.
DECIMALS ± .010"

MATERIAL:
TOLERANCES DO NOT APPLY TO RAW MATERIAL



12' HC PLATFORM WITH COLLARS & ENHANCED SUPPORT RAIL FITS 10"Ø TO 40"Ø MONOPOLES

REV	DATE	DRW/CHK	DESCRIPTION
1	04/18/16	WRF/KLE	DESIGN UPDATE

CONFIDENTIAL
This document and the information contained herein is the confidential trade secret property of Sabre Communications Corporation ("Sabre") and must not be reproduced, copied or used, in whole or in part, for any purpose without the prior written consent of Sabre.
© 2016 Sabre Communications Corporation. All rights reserved.

DATE	02/16/16	SIZE	DRAWING NO.	REV	
		B	C10855661C	1	
DRAWN BY	WRF	CHECKED BY	KLE	SCALE	None
				PAGE	1 OF 3

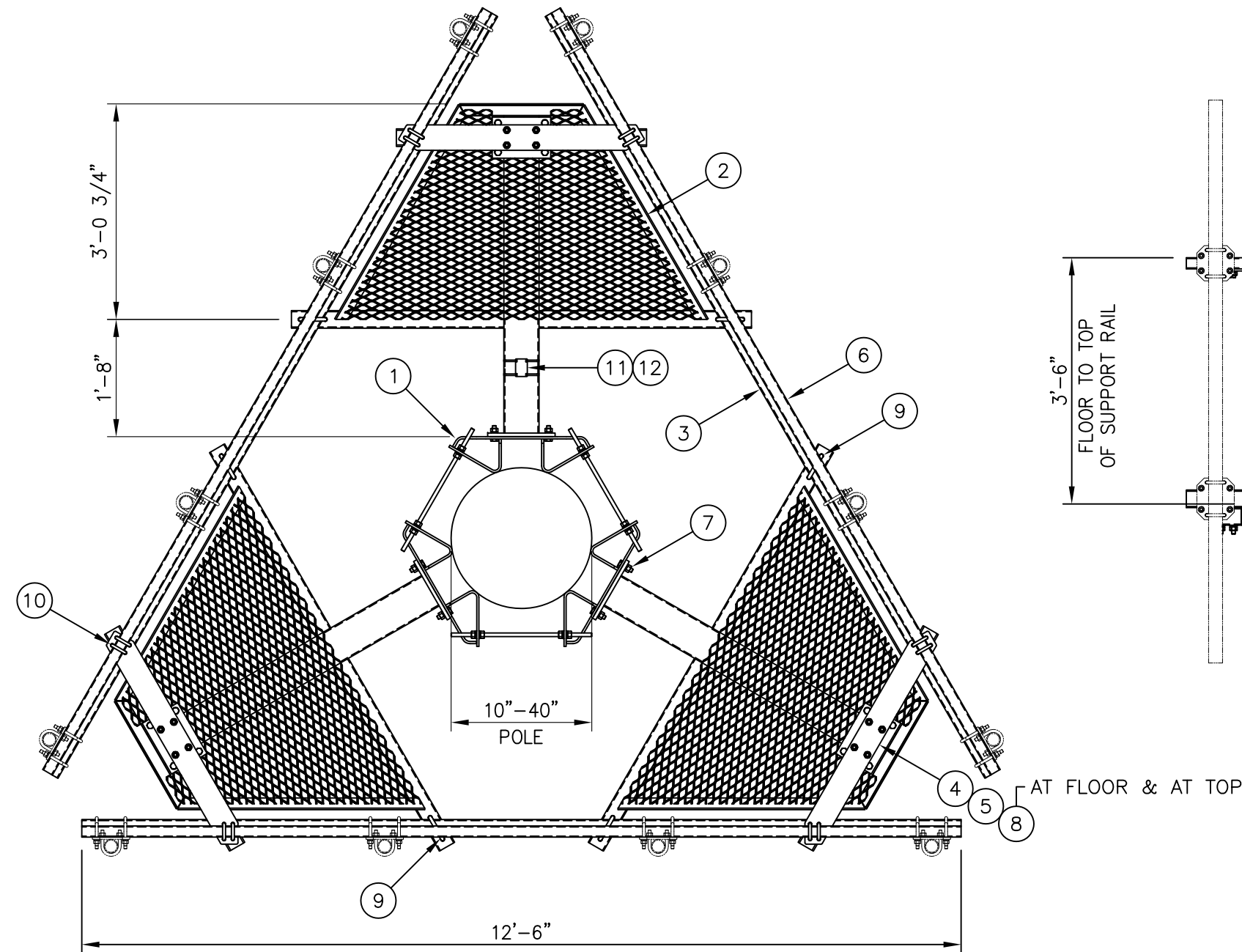

PLAN VIEW

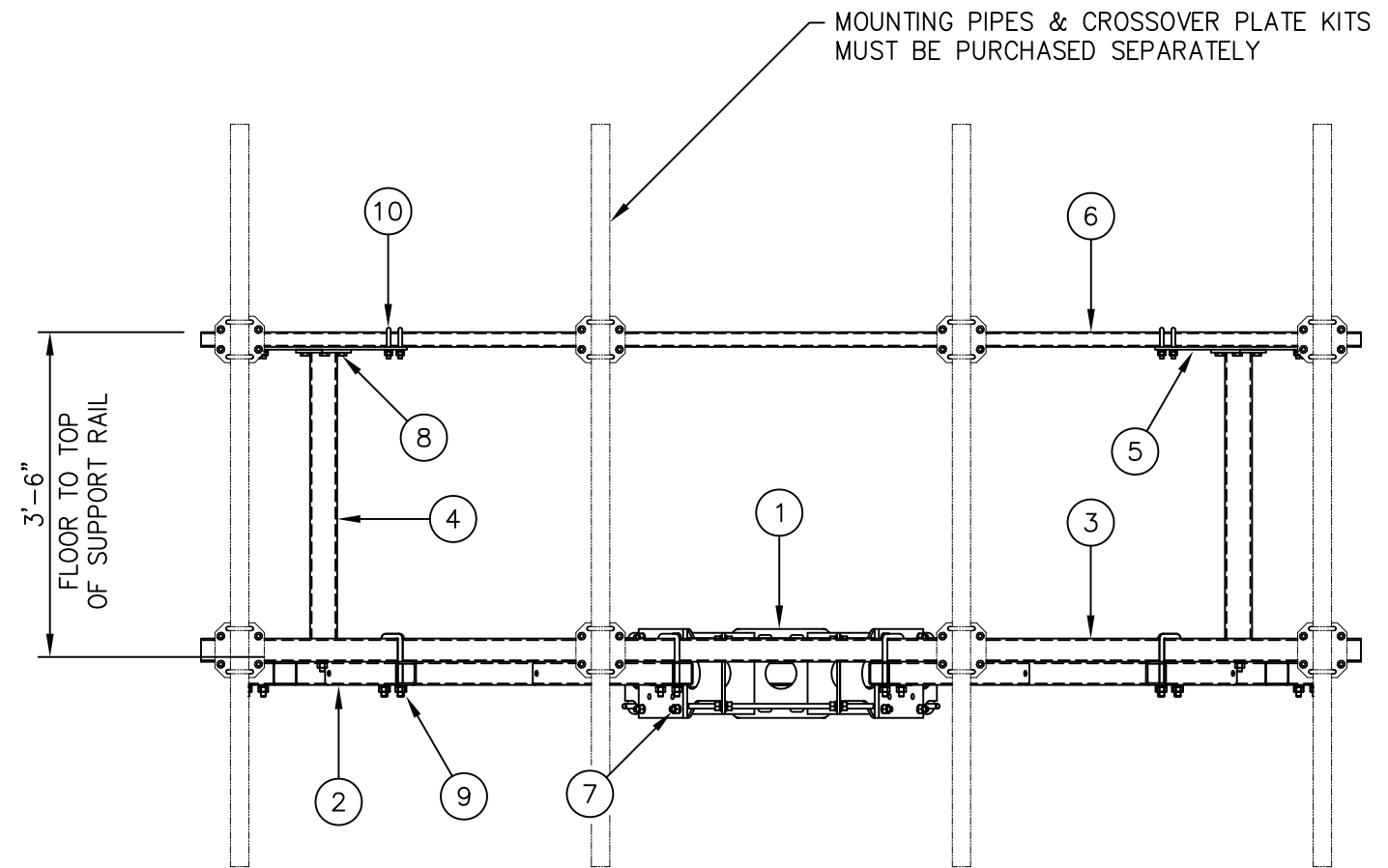

FRONT VIEW

UNLESS OTHERWISE SPECIFIED
ALL DIMENSIONS INCLUDE
FINISHES AND ARE IN INCHES
TOLERANCES: FRACTIONS $\pm 1/16''$
ANGLES $\pm 1/2$ DEG.
DECIMALS $\pm .010''$

MATERIAL:
TOLERANCES DO NOT APPLY
TO RAW MATERIAL



12' HC PLATFORM WITH COLLARS
& ENHANCED SUPPORT RAIL
FITS 10"Ø TO 40"Ø MONOPOLES

REV	DATE	DRW	CHK	DESCRIPTION
1	04/18/16	WRF	KLE	DESIGN UPDATE

CONFIDENTIAL
This document and the information
contained herein is the confidential trade
secret property of Sabre Communications
Corporation ("Sabre") and must not be
reproduced, copied or used, in whole or in
part, for any purpose without the prior
written consent of Sabre.
© 2016 Sabre Communications Corporation.
All rights reserved.

DATE	02/16/16	SIZE	B	DRAWING NO.	C10855661C	REV	1
DRAWN BY	WRF	SCALE	None	PAGE	2 OF 3		
CHECKED BY	KLE						

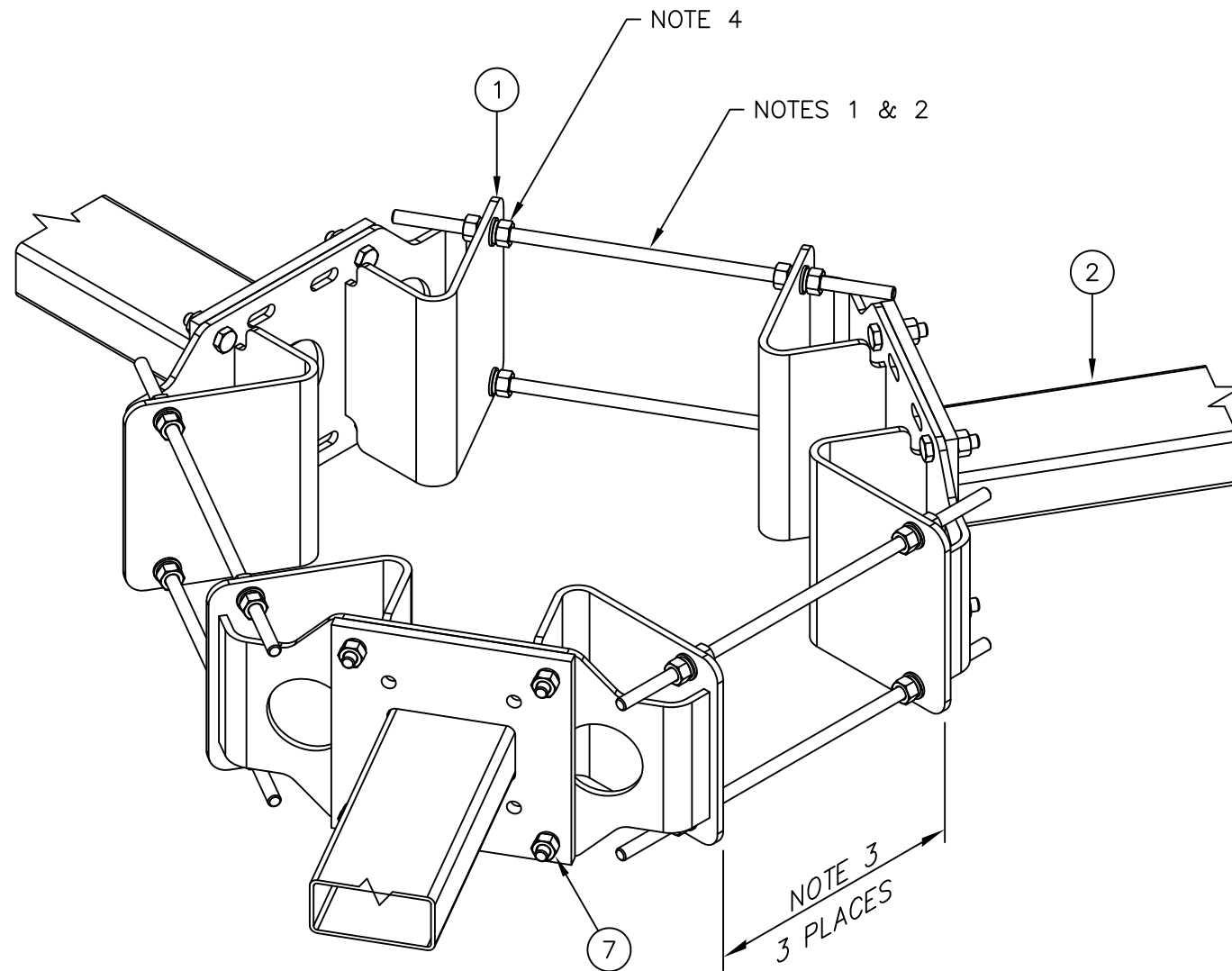

TRI-COLLAR NOTES:

1. THERE ARE (2) LENGTHS OF THREADED ROD SUPPLIED TO ACCOMMODATE DIAMETERS LISTED BELOW.
 USE 5/8 X 1'-6" THREADED ROD ASSEMBLY FOR 10"-24" MONOPOLE DIAMETERS.
 USE 5/8 X 2'-9" THREADED ROD ASSEMBLY FOR 24"-40" MONOPOLE DIAMETERS (SEE NOTE 2).
2. THREADED ROD MAY BE SHORTENED IF REQUIRED, FIELD CUT AND COLD GALV SPRAY TO SUIT.
3. THIS DISTANCE MUST BE EQUAL IN ALL (3) THREE LOCATIONS TO ENSURE THE STRUCTURAL INTEGRITY OF THE THREADED RODS AS WELL AS 120° SEPARATION.
4. FOR MONOPOLES 13" DIA. OR SMALLER, ONLY (1) ONE NUT AND (1) ONE LOCKWASHER ARE REQUIRED BETWEEN THE TRI-COLLAR BRACKETS.
 FOR MONOPOLES LARGER THAN 13" DIA., (2) TWO NUTS AND (2) TWO LOCKWASHERS ARE REQUIRED BETWEEN THE TRI-COLLAR BRACKETS.

TRI-COLLAR DETAIL

UNLESS OTHERWISE SPECIFIED ALL DIMENSIONS INCLUDE FINISHES AND ARE IN INCHES		MATERIAL:				12' HC PLATFORM WITH COLLARS & ENHANCED SUPPORT RAIL FITS 10"Ø TO 40"Ø MONOPOLES				
TOLERANCES: FRACTIONS ± 1/16" ANGLES ± 1/2 DEG. DECIMALS ± .010"		TOLERANCES DO NOT APPLY TO RAW MATERIAL								CONFIDENTIAL This document and the information contained herein is the confidential trade secret property of Sabre Communications Corporation ("Sabre") and must not be reproduced, copied or used, in whole or in part, for any purpose without the prior written consent of Sabre. © 2016 Sabre Communications Corporation. All rights reserved.
REV	DATE	DRW	CHK	DESCRIPTION	DATE	DRAWN BY	CHECKED BY	SIZE	DRAWING NO.	REV
1	04/18/16	WRF	KLE	DESIGN UPDATE	02/16/16	WRF	KLE	B	C10855661C	1
									SCALE None	PAGE 3 OF 3