

ITEM	QTY.	DWG. NO.	DESCRIPTION	APPROX. GALV. WEIGHT	WEIGHT
6.	16	C40034028	U-BOLT ASSEMBLY, 5/8"φ X 4 3/16 C/C		30.7#
5.	4	C40026025	BOLT ASSEMBLY, 5/8"φ X 2 1/2 A325		1.9#
4.	4	CS00071	PIPE CROSSOVER PLATE		32.0#
3.	1	CS00038	T-ARM CROSSOVER PLATE		22.0#
2.	1	CW00016	SUPPORT PIPE		109.0#
1.	1	CW00144	T-ARM WELDMENT		64.9#

**LIST OF MATERIAL**

**NOTES:**

1. TRI-COLLAR MOUNTS MUST BE PURCHASED SEPARATELY.
2. 2 3/8" O.D. MOUNTING PIPE & U-BOLTS MUST BE PURCHASED SEPARATELY.
3. FOUR (4) PIPE CROSSOVER PLATES ARE SUPPLIED WITH EACH T-ARM ASSEMBLY, REGARDLESS OF QUANTITY OF PIPES PURCHASED.
4. QUANTITIES SHOWN IN LIST OF MATERIAL ARE FOR ONE (1) T-ARM ASSEMBLY ONLY.

UNLESS OTHERWISE SPECIFIED ALL DIMENSIONS INCLUDE FINISHES AND ARE IN INCHES			MATERIAL:		
TOLERANCES: FRACTIONS ± 1/16"			TOLERANCES DO NOT APPLY TO RAW MATERIAL		
ANGLES ± 1/2 DEG.					
DECIMALS ± .010"					
REV	DATE	DRW/CHK	DESCRIPTION		

		<p align="center"><b>T-ARM ASSEMBLY</b> 3'-0" ARM WITH 12'-0" FACE</p>				
						DATE
<p align="center"><b>CONFIDENTIAL</b> This document and the information contained herein is the confidential trade secret property of Sabre Communications Corporation ("Sabre") and must not be reproduced, copied or used, in whole or in part, for any purpose without the prior written consent of Sabre. © 2014 Sabre Communications Corporation. All rights reserved.</p>		DRAWING NO.	C10113184		REV	0
DRAWN BY	JKW	SCALE	None		PAGE	1 OF 1
CHECKED BY	MLC					



C10112301 TRI-COLLAR ASSEMBLY (12"-60" MONOPOLE)

ITEM	QTY.	PART. NO.	DESCRIPTION	WEIGHT
1.	3	CW00843	WELDMENT, TRI-COLLAR (12"-60" MONOPOLE)	294
2.	6	C40094010	THREADED ROD ASSEMBLY 3/4 X 4'-4"	36
TOTAL WEIGHT				330

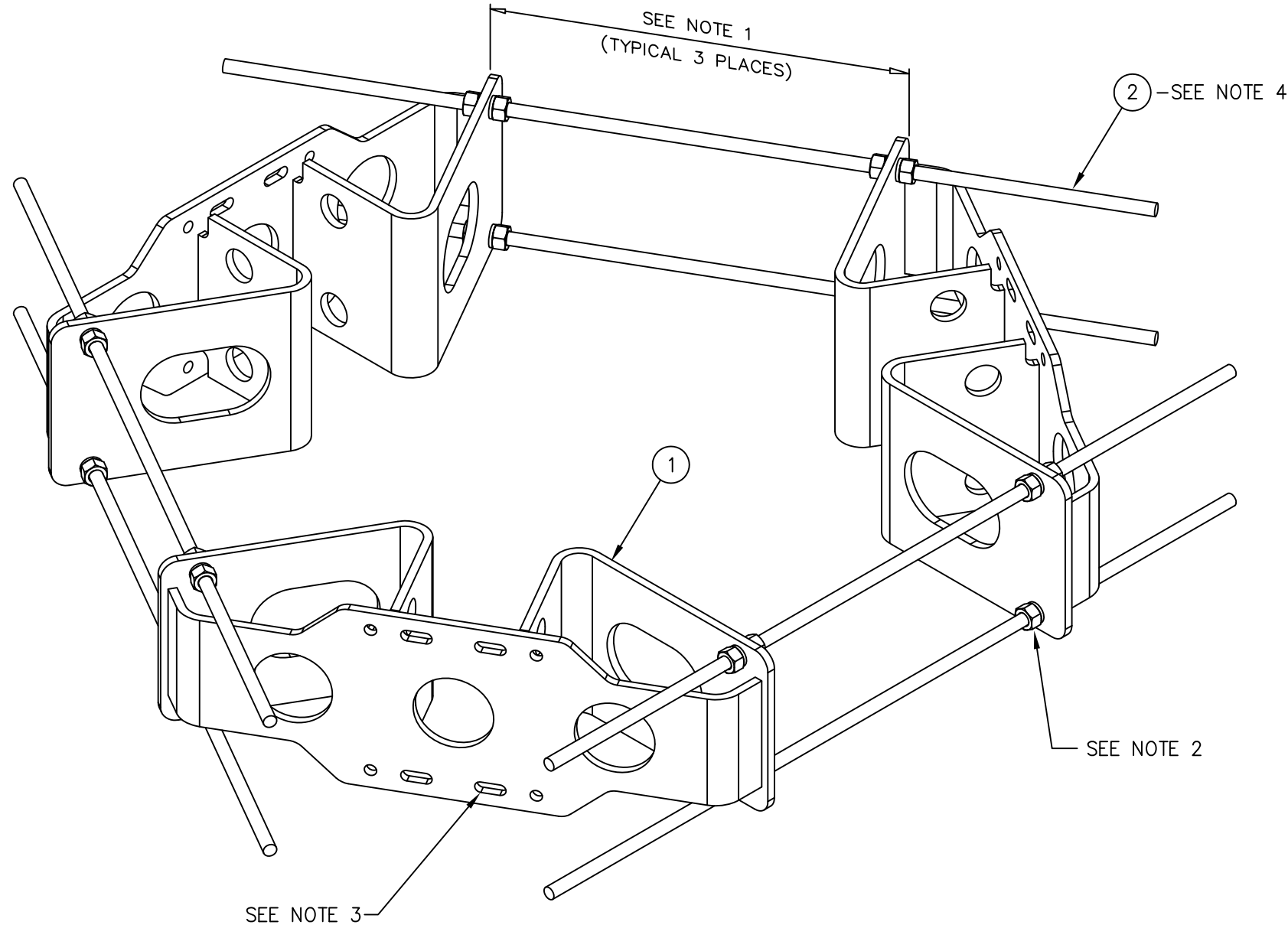

ISOMETRIC VIEW

NOTES:

1. THIS DISTANCE MUST BE EQUAL IN ALL (3) THREE LOCATIONS TO ENSURE THE STRUCTURAL INTEGRITY OF THE THREADED RODS AS WELL AS 120° SEPARATION.
2. FOR MONOPOLES 13" DIA. OR SMALLER, ONLY (1) ONE NUT AND (1) ONE LOCKWASHER ARE REQUIRED BETWEEN THE TRI-COLLAR BRACKETS. FOR MONOPOLES LARGER THAN 13" DIA., (2) TWO NUTS AND (2) TWO LOCKWASHERS ARE REQUIRED BETWEEN THE TRI-COLLAR BRACKETS.
3. THE MOUNTING SLOTS NOTED WILL ACCOMMODATE 2 3/8"-4 1/2" O.D. MOUNTING PIPES.
4. THREADED ROD MAY BE SHORTENED IF REQUIRED, FIELD CUT AND COLD GALV SPRAY TO SUIT.

UNLESS OTHERWISE SPECIFIED  
ALL DIMENSIONS INCLUDE  
FINISHES AND ARE IN INCHES  
TOLERANCES: FRACTIONS ± 1/16"  
ANGLES ± 1/2 DEG.  
DECIMALS ± .010"

MATERIAL:  
  
TOLERANCES DO NOT APPLY  
TO RAW MATERIAL



TRI-COLLAR BRACKET ASSEMBLY  
FOR MONOPOLES (12"-60" DIA.)  
(CIRCUMFERENCE 37.7" TO 188.5")

REV	DATE	DRW	CHK	DESCRIPTION
1	1/6/10	MLC	MC	REDRAWN IN AUTOCAD

**CONFIDENTIAL**  
This document and the information contained herein is the confidential trade secret property of Sabre Communications Corporation ("Sabre") and must not be reproduced, copied or used, in whole or in part, for any purpose without the prior written consent of Sabre.  
© 2014 Sabre Communications Corporation. All rights reserved.

DATE	8/21/09	SIZE B	DRAWING NO. C10112301	REV	1
DRAWN BY	JV			SCALE	PAGE
CHECKED BY	MLC	None	1 OF 1		