

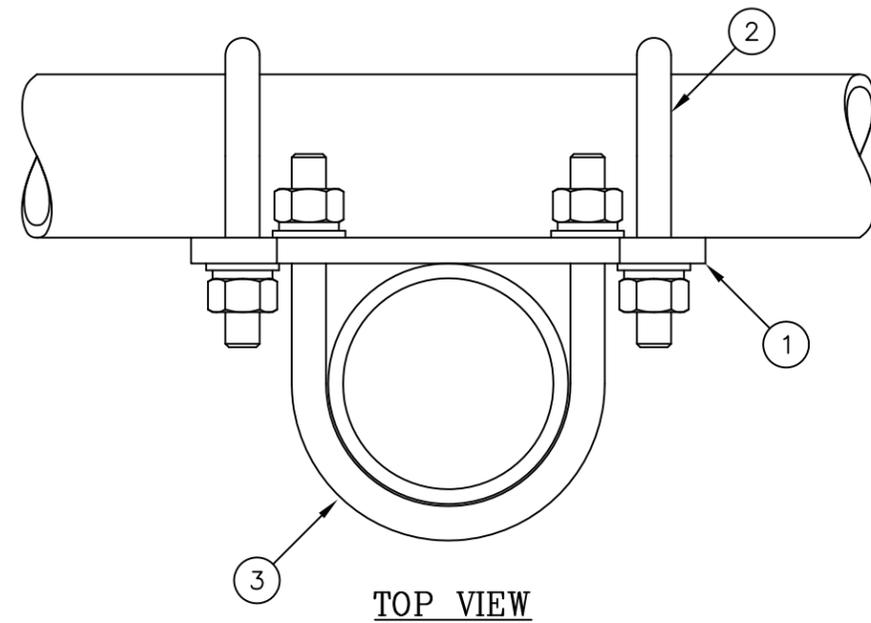

C10902013 CROSSOVER PLATE KIT

ITEM	QTY.	PART NO.	DESCRIPTION	WEIGHT
1.	1	CS03123	CROSSOVER PLATE	5
2.	2	C40034139	U-BOLT ASSEMBLY, 1/2" ϕ X 2 15/16" C-C	2
3.	2	C40034143	U-BOLT ASSEMBLY, 1/2" ϕ X 4 1/16" C-C	2
TOTAL WEIGHT				9



TOP VIEW

3 1/2" ϕ PIPE

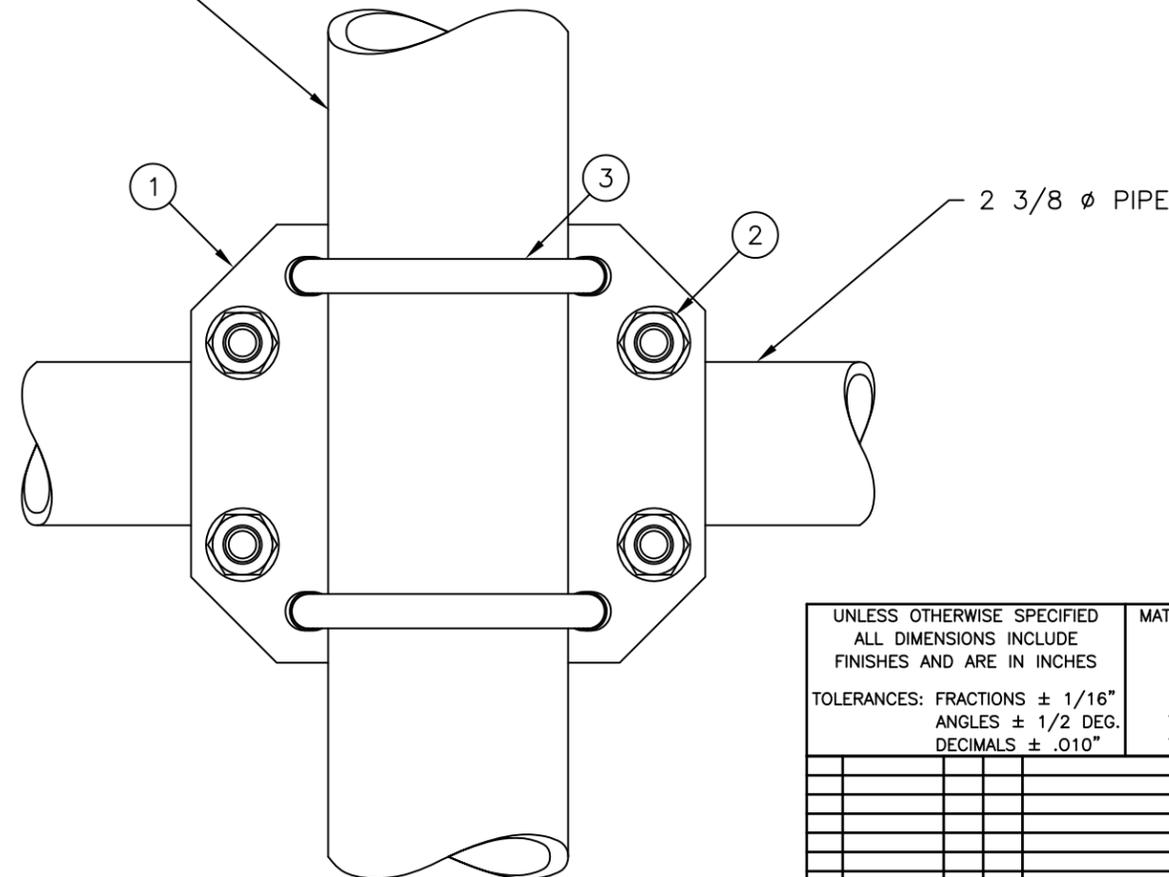

FRONT VIEW

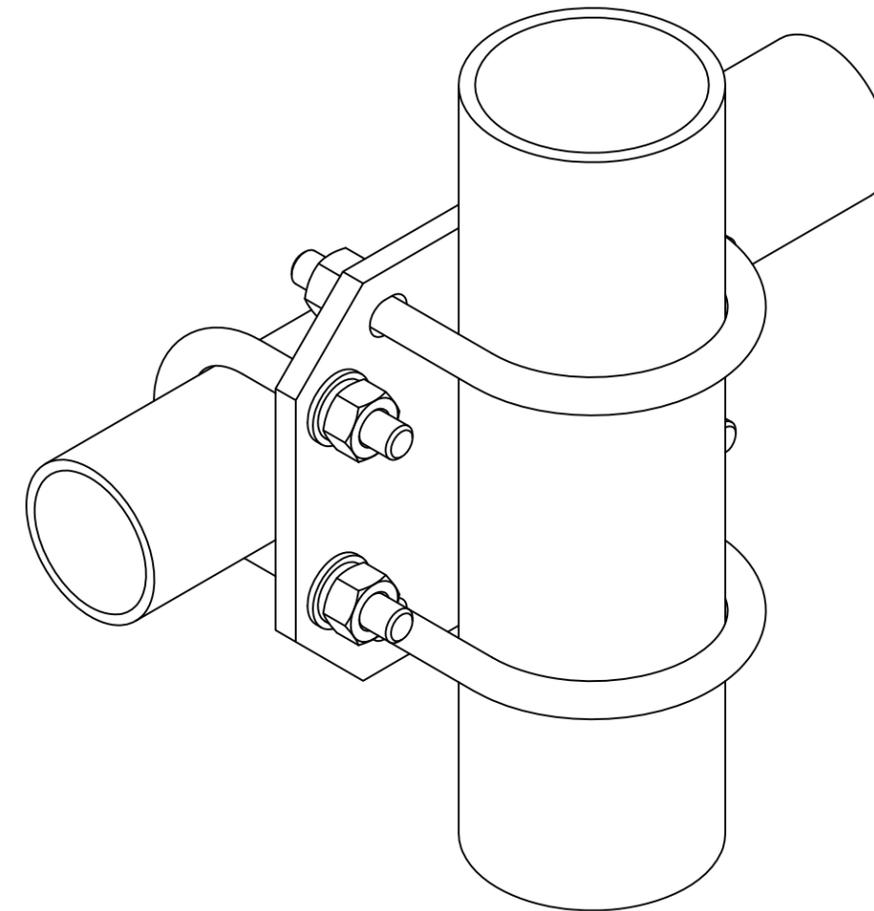

ISOMETRIC VIEW

UNLESS OTHERWISE SPECIFIED
ALL DIMENSIONS INCLUDE
FINISHES AND ARE IN INCHES
TOLERANCES: FRACTIONS $\pm 1/16"$
ANGLES $\pm 1/2$ DEG.
DECIMALS $\pm .010"$

MATERIAL:
TOLERANCES DO NOT APPLY
TO RAW MATERIAL



CROSSOVER PLATE KIT
2 3/8" ϕ TO 3 1/2" ϕ PIPES
(1/2" ϕ U-BOLTS)

REV	DATE	DRW/CHK	DESCRIPTION

CONFIDENTIAL
This document and the information
contained herein is the confidential trade
secret property of Sabre Communications
Corporation ("Sabre") and must not be
reproduced, copied or used, in whole or in
part, for any purpose without the prior
written consent of Sabre.
© 2014 Sabre Communications Corporation.
All rights reserved.

DATE	07/23/14	SIZE	DRAWING NO.	REV
DRAWN BY	WRF	B	C10902013	0
CHECKED BY	KLE		SCALE	PAGE
			None	1 OF 1