

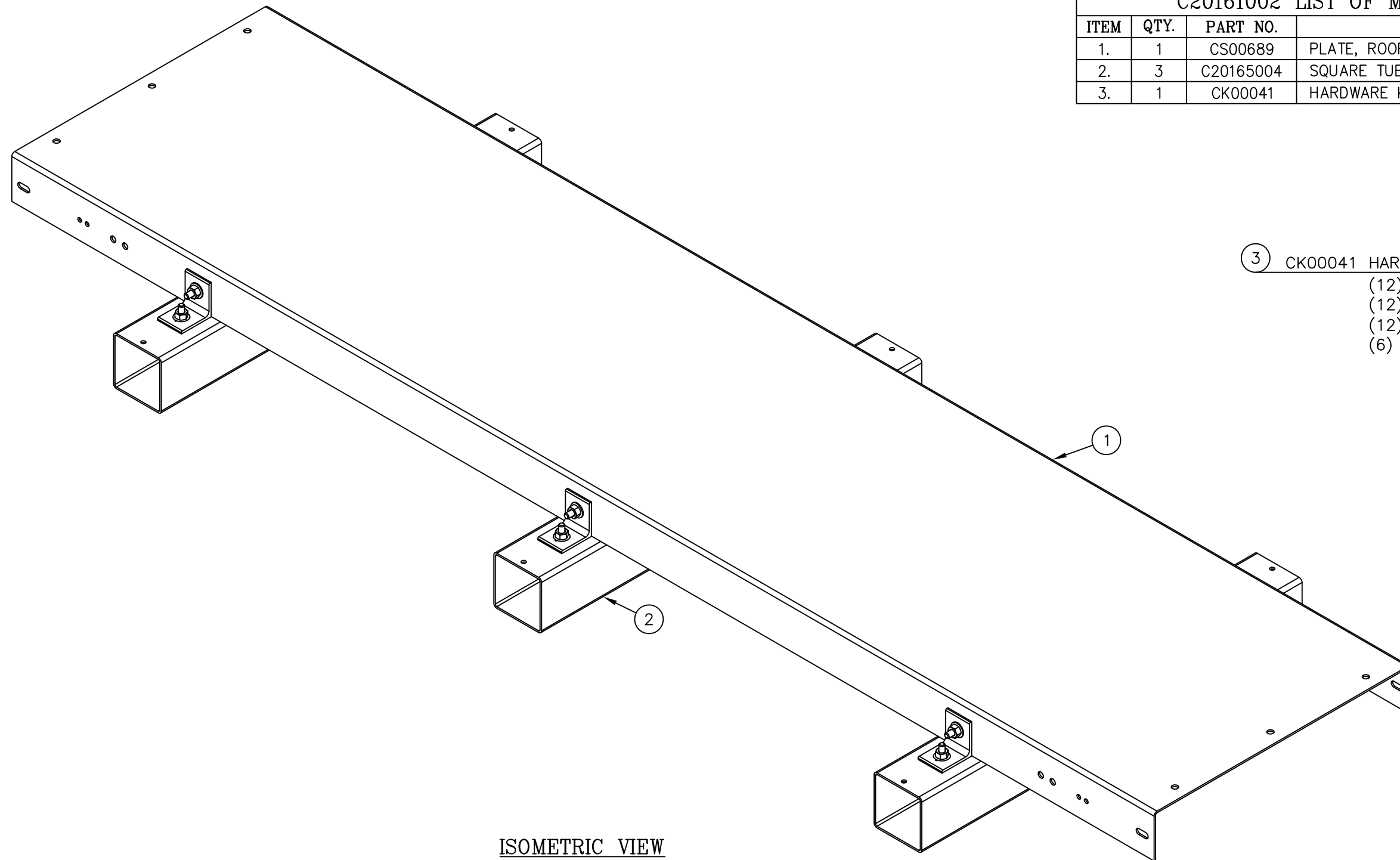

C20161002 LIST OF MATERIAL FOR ROOFTOP BRIDGE

ITEM	QTY.	PART NO.	DESCRIPTION	WEIGHT
1.	1	CS00689	PLATE, ROOFTOP BRIDGE COVER	85#
2.	3	C20165004	SQUARE TUBE, ROOFTOP BRIDGE SLEEPER (PVC)	8#
3.	1	CK00041	HARDWARE KIT (SEE BELOW FOR LIST)	5#
TOTAL WEIGHT				98#



ISOMETRIC VIEW

- ③ CK00041 HARDWARE KIT INCLUDES:
 (12) 3/8"-16 X 1 1/4" BOLT ASSEMBLY GR.5
 (12) 3/8" FLATWASHER
 (12) 3/8"-16 NYLON RETAINING NUT
 (6) CLIP ANGLE (sabre738)

UNLESS OTHERWISE SPECIFIED
 ALL DIMENSIONS INCLUDE
 FINISHES AND ARE IN INCHES
 TOLERANCES: FRACTIONS ± 1/16"
 ANGLES ± 1/2 DEG.
 DECIMALS ± .010"

MATERIAL:
 TOLERANCES DO NOT APPLY
 TO RAW MATERIAL



8 COAX ROOFTOP BRIDGE
 (21 1/2" WIDE X 8' LONG)

REV	DATE	DRW	CHK	DESCRIPTION
1	6/23/10	KLE	EK	ITEM 1 REVISED MATERIAL GAGE (WAS 11 GA.)

CONFIDENTIAL
 This document and the information
 contained herein is the confidential trade
 secret property of Sabre Communications
 Corporation ("Sabre") and must not be
 reproduced, copied or used, in whole or in
 part, for any purpose without the prior
 written consent of Sabre.
 © 2008 Sabre Communications Corporation.
 All rights reserved.

DATE	1/14/08	SIZE	B	DRAWING NO.	C20161002	REV	1
DRAWN BY	JV/MLC	SCALE	None	PAGE	1 OF 1		
CHECKED BY	MC						